

LED LIGHT PANEL SPECIFICATIONS

THE SPECIFICATIONS

ELECTRICAL PROPERTIES	LED Chip Manufacturer	Toyoda Gosei Japan
	Input Voltage	12 Volt DC
	Power Consumption	0.25 Watts / LED
	Configuration	Standard = 18 LEDs per ft. / illuminated edge High Output = 24 LEDs per ft. / illuminated edge
	Electrical Connection	Wire Size: 22 AWG 2 Wire Connector: 2.1mm x 5.5mm barrel connector Polarity: Positive Center
Wiring	Each panel must have direct connection to power supply. Panels cannot be wired in series.	

PHYSICAL PROPERTIES	Color Options	Standard: Cool White (5300-K) Standard: Warm White (3700-K) High Output: Cool White (5300-K)
	Operating Temperature	-30°C to +85°C
	Minimum Size	1.5"W x 3"L x 5/16"D (38mm x 76mm x 8mm)
	Maximum Size	48"W x 96"L x 5/16"D (1219mm X 2438mm x 8mm)

MECHANICAL PROPERTIES	Tensile Strength	760 Kg/cm ²
	Elongation	6%
	Flexural Strength	1170 Kg/cm ²
	Flexural Modulus	32000 Kg/cm ²
	Izod Impact Strength	2 Kg cm/cm
	Rockwell Hardness	95 (Mscale)
	Weight	1.95lbs / sq.ft

DIAGRAMS

LED LIGHT PANEL FACE VIEW

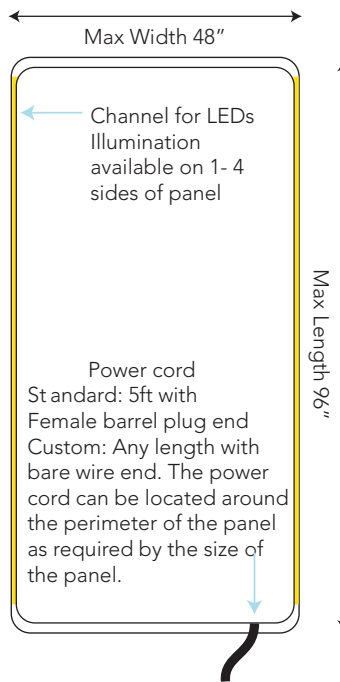

LED LIGHT PANEL PROFILE VIEW

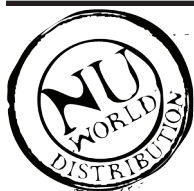
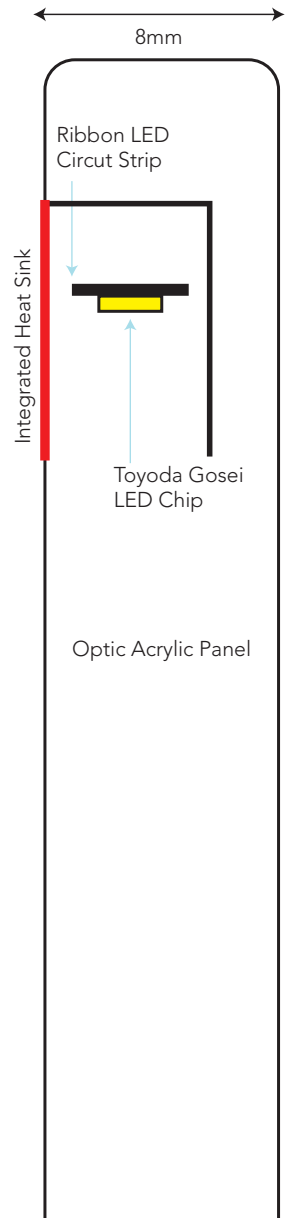

1140 Cloverley Street
North Vancouver, BC, V7L 1N6
T: 778 991 6049
E: info@nu-worlddistribution.com
www.nu-wo.com

NOTES Damage may be caused by a damaged or improper drill bit, excess strain on the panel, drilling too close to the edges of the panel as well as many other factors. Drilling holes in the LED panel is done at the sole discretion of the installer and Nu World takes no responsibility for damage caused by this action.

LED LIGHT PANEL SPECIFICATIONS

HARDWARE INSTALLATION

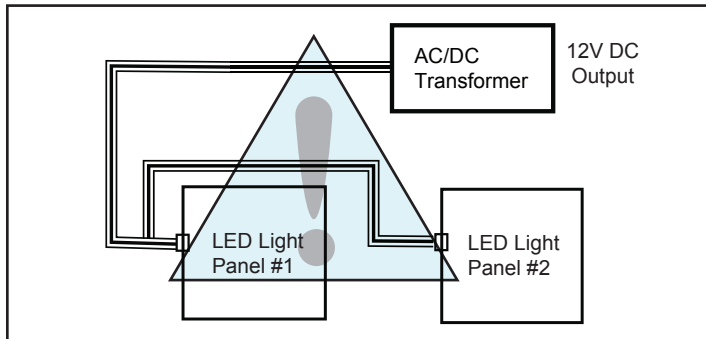
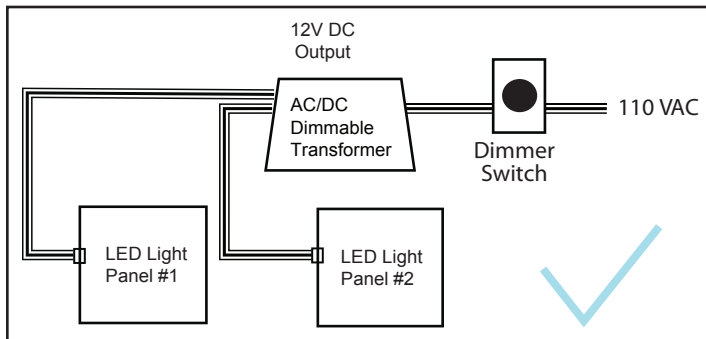
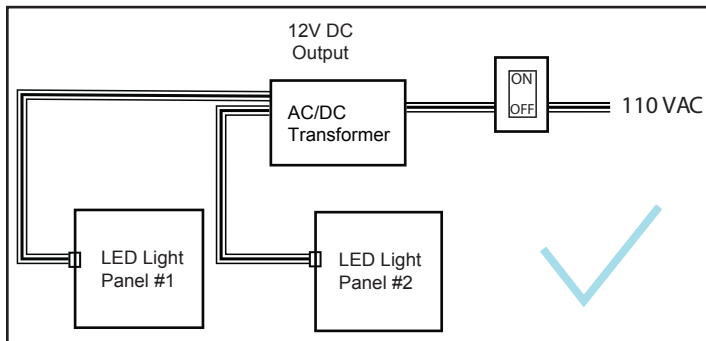
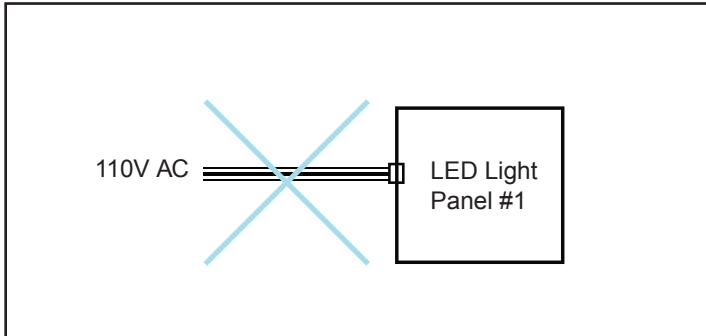

Only use Nu World approved 12 Volt DC transformers to power the LED light panels.

When wiring the LED light panels to a hardwire, 12 Volt DC transformer, all panels must be "home run" directly to the power transformer. The total combined wattage of the LED panels must not exceed the maximum rating of the transformer. The transformer voltage input should be wired to a standard household AC voltage line switch. (120VAC for North America).

When using the dimmable 12 Volt DC transformer, the transformer voltage input should be wired to a standard household AC voltage dimmer switch.

If wiring the panels in series, it is important to be aware that voltage loss will occur over longer runs which will affect the light intensity of the panels. Panels which are further away from the power supply will be less bright than those close to the power supply.

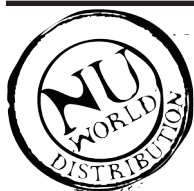

1140 Cloverley Street
 North Vancouver, BC, V7L 1N6
 T: 778 991 6049
 E: info@nu-worlddistribution.com
 www.nu-wo.com

NOTES

LED LIGHT PANEL SPECIFICATIONS

PLACEMENT INSTALLATION

Nu World LED light panels may be mounted to the wall, ceiling or floor by several means. Mounting clips and fasteners such as "mirror clips" or other similar hardware may be used to secure the LED panel. Be careful not to apply too much pressure on the acrylic panel as it may crack or break under stress.

Nu World LED panels are designed with unique heat sinks which dissipate the heat generated by the LEDs. This allows the panel to be directly mounted to walls by drilling holes at locations on the panel that are away from the sides where the LED lights and heat sinks are located. A minimum distance of 2" from the edges of the panel is recommended.



PLUG-IN POWER ADAPTOR

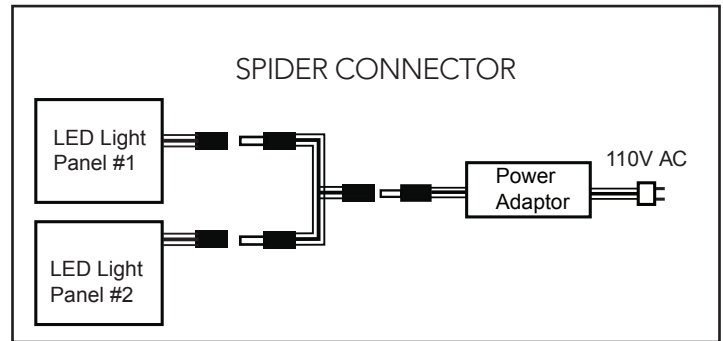
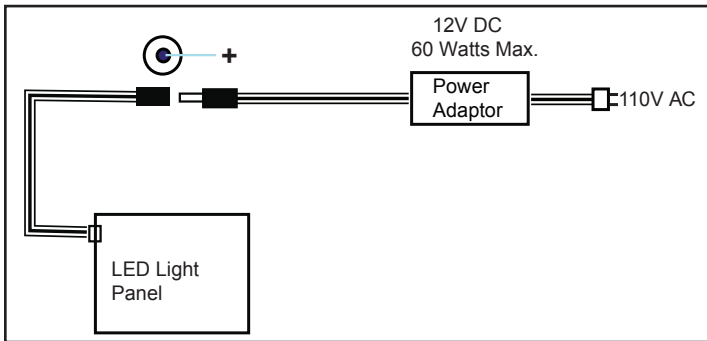

PLUG-IN POWER ADAPTOR WIRING WITH DIMMER MODULE

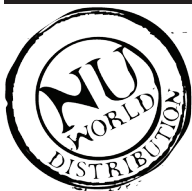
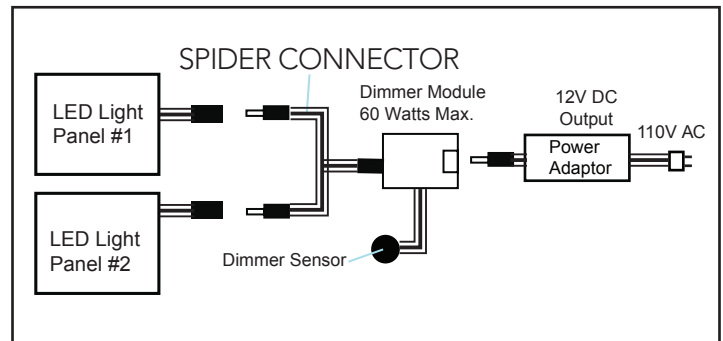
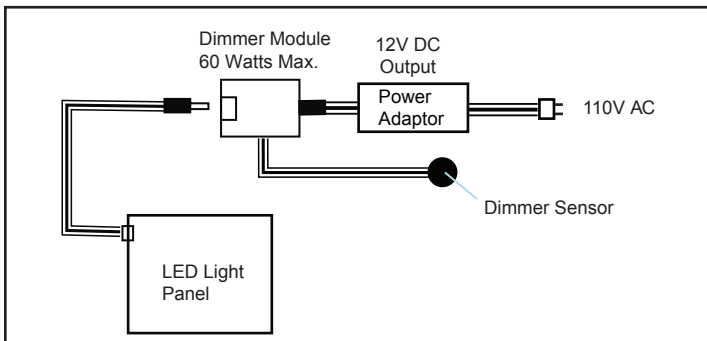

1140 Cloverley Street
 North Vancouver, BC, V7L 1N6
 T: 778 991 6049
 E: info@nu-worlddistribution.com
 www.nu-wo.com

NOTES Combined total wattage of LED light panels must be below the maximum rating of the Power Adaptor

LED LIGHT PANEL SPECIFICATIONS

POWER SUPPLIES



AMP	1 AMP
DVE	DVE Switching adaptor
Input	100-240VAC 50/60hz, 0.3A
Output	12VDC, 1.0A, 12W
Approvals	UL, CUL
Dimensions	1 3/4" x 2/3" x 1 1/8"



Type	Dimming Magnetic Transformer
AMP	5 AMP
Input	120, 240, 277VAC 50/60Hz
Output	12VDC, 5A, 60W
Approvals	UL, cUL, CE, ETL, RoHS, Class 2
Dimensions	3" x 6 15/16" x 3 3/4"



AMP	3 AMP
DVE	DVE Switching adaptor
Input	100-240VAC 50/60hz, 1.2A
Output	12VDC, 3.0A, 36W
Approvals	UL, CUL Level 3
Dimensions	2 1/4" x 4" x 1 3/8"

Nu World LED light panels are powered by 12 Volt DC power adaptors and transformers. There are several options available to power the LED light panels including Plug-in power adaptors and hardwire transformers.



AMP	5 AMP
DVE	DVE Switching adaptor
Input	100-240VAC 50/60hz, 1.5A
Output	12VDC, 5.0A, 60W
Approvals	UL, cUL, CE, FCC, CCC
Dimensions	1 3/4" x 2/3" x 1 1/8"

When choosing the plug-in power adaptor option, Nu World will send the appropriate power supply together with your LED light panel. When choosing the hardwire option, you can select between dimmable and non-dimmable power transformer options. It is important to ensure that the power draw of the LED light panel does not exceed the maximum rating of the power supplies provided, failure to do so can result in damage to the LED light panel and/or power supply. Any wiring from the power adaptor or transformer to the LED light panel should be kept as short as possible to avoid any voltage drop.



Type	Hardwire Transformer
AMP	10 AMP
Input	120, 240VAC 50/60Hz
Output	12VDC, 10A, 120W
Approvals	UL, cUL, CE
Dimensions	2 9/16" x 4 15/16" x 3 15/16"

All power supplies are cUL and UL listed for safety and conformity to electrical codes

Do not apply any voltage other than 12 Volt DC power to the fixture as it may cause damage and void the Warranty. Warranty is void if using power adaptors or transformers not approved by Nu World Distribution.

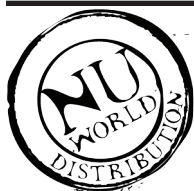

1140 Cloverley Street
North Vancouver, BC, V7L 1N6
T: 778 991 6049
E: info@nu-worlddistribution.com
www.nu-wo.com

NOTES

LED LIGHT PANEL SPECIFICATIONS

ACCESSORIES

SPIDER CONNECTOR:

One power adaptor can supply power to multiple LED light panels as long as the total wattage of the LED light panels is less than the maximum wattage of the power adaptor.

In this case, a convenient way of connecting multiple panels is to use a Nu World spider connector. There are 3 kinds of spider connectors (2-way, 4-way, and 6-way). The 2-way and 4-way connectors have long cables, while the 6-way connector has a short cable between each DC plug.

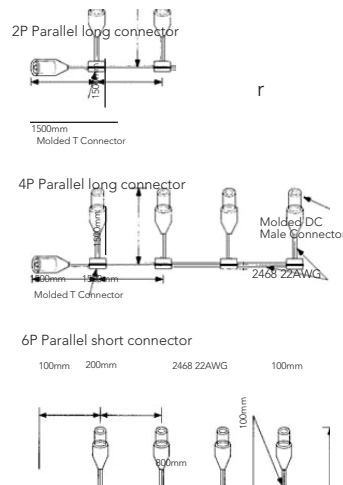

DIMMER MODULE:

Nu World LED light panels can be dimmed with a Nu World DC dimmer module. The dimmer module consists of 3 components: dimmer main body, a sensor and a wireless remote control.

Securely connect the DC plug of power adaptor and the DC plug of the panels to the dimmer main body. Plug the sensor into the dimmer main body. Remove the battery protection sheet in the remote control. Point the remote control at the sensor to dim the panels. (Max/Min/On/O_ +/-). The dimmer capacity is up to 60W each. Larger panels with two power connectors with the total wattage exceeding 60W require 2 dimmer modules.

To control multiple panels with one remote control pad, put all sensors together in the same area. Multiple LED light panels can be controlled with 1 dimmer module as long as the total wattage of all panels is less than 60W.

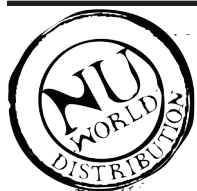

1140 Cloverley Street
North Vancouver, BC, V7L 1N6
T: 778 991 6049
E: info@nu-worlddistribution.com
www.nu-wo.com

NOTES
